



MT5A61-01

TI IWR1642 77GHz

mmWave Sensor device

Datasheet

Draft 0.1

Prepared By	Reviewed By	Approved By

Index

1. INTRODUCTION	2
1.1. GENERAL FEATURES	2
1.2. OVERVIEW	3
2. HARDWARE INFORMATION	4
2.1. BLOCK DIAGRAM	4
2.2. CONNECTOR PIN DEFINE	5
2.3. RECOMMENDED OPERATING	7
2.4. POWER CONSUMPTION	7
3. ANTENNA PERFORMANCE	8
4. REFERENCE DESIGN	9
4.1. REFERENCE SCHEMATIC	9
4.2. MMWAVE ANTENNA NOTE	10
5. FUNCTION DESCRIPTION	11
5.1. MEMORY FLASHING	11
5.2. TESTING SETUP	12
6. DEVICE DIMENSION	13
7. SOFTWARE INFORMATION	14
7.1. SOFTWARE DEVELOPMENT KIT	14
7.2. PROGRAMMING TOOL	14
7.3. APPLICATION RESOURCE	14
8. ORDERING INFORMATION	14
9. HISTORY CHANGE	14

1. INTRODUCTION

The MT5A61-01 is the sensor device which integrates Texas Instruments' industrial mmWave technology. This device targets low power and ultra-accurate mmWave systems in security, industrial, and personal health care applications.

The MT5A61-01 simplifies the implementation of mmWave sensors in the band of 76 to 81GHz, and it includes the ARM Cortex-R4F based processor system, 2Tx 4Rx antenna and Onboard PMIC with specific SDK (Software Development Kit) for diverse applications, such as environment monitor, equipment inspection and maintain, personal health care, and objects' detection.

1.1. General Features

- Built-in Antenna
- Onboard PMIC
- 2.54mm female pin header
- 5V Power-in
- Dimensions: 50 mm (L) x 34 mm (W) x 7.5 mm (H)

1.2. Overview

Figure 1-1 to 1-2 shows the MT5A61-01 sensor Device.

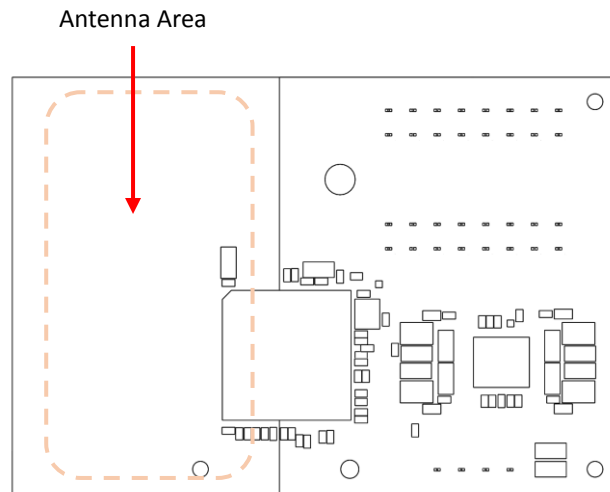

Figure 1-1. MT5A61-01 Front View

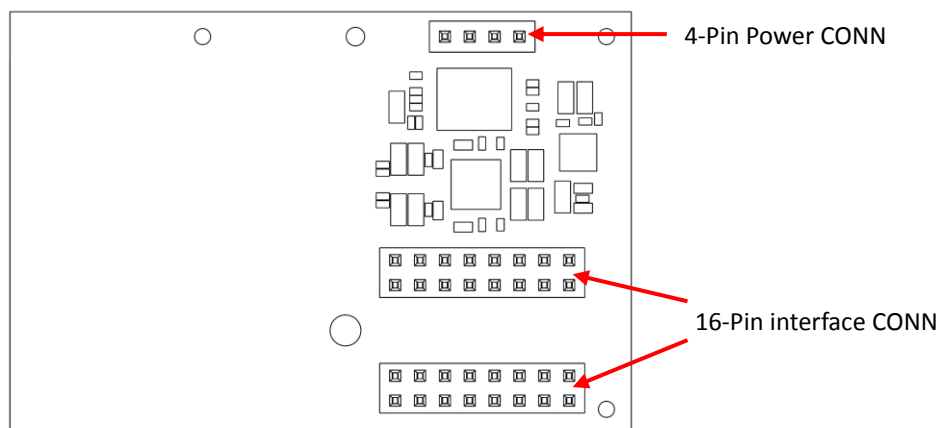

Figure 1-2. MT5A61-01 Back View

2. HARDWARE INFORMATION

2.1. Block Diagram

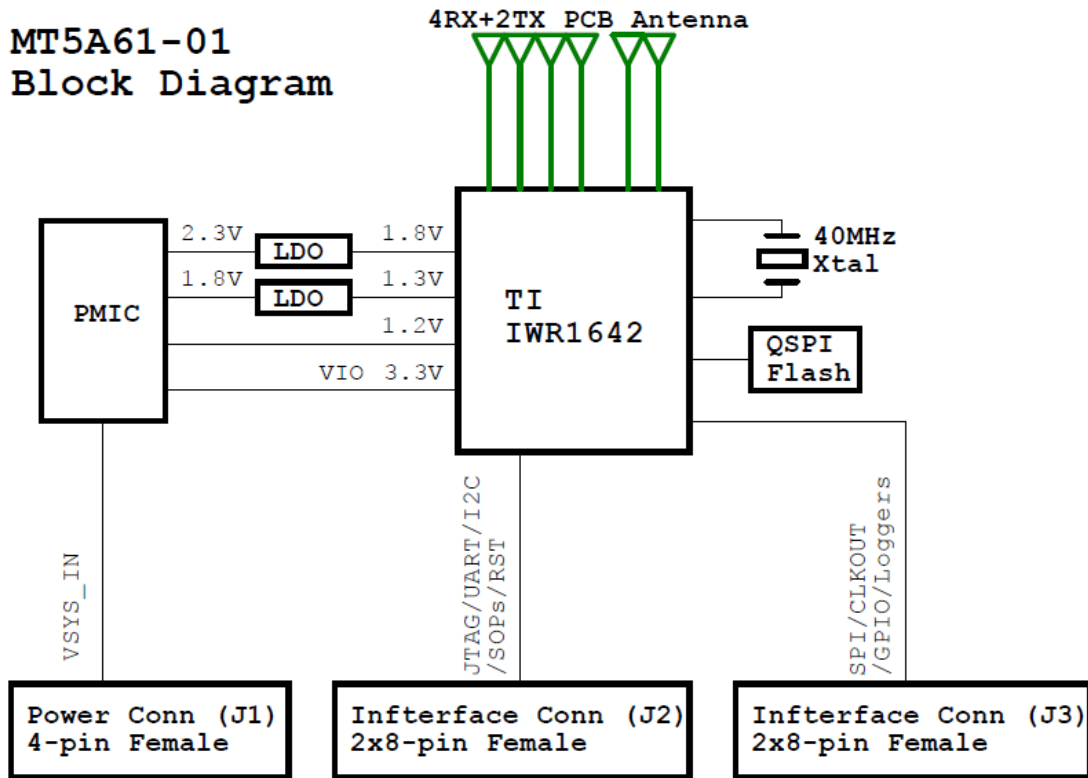

Figure 2-1. MT5A61-01 Block Diagram

2.2. Connector Pin Define

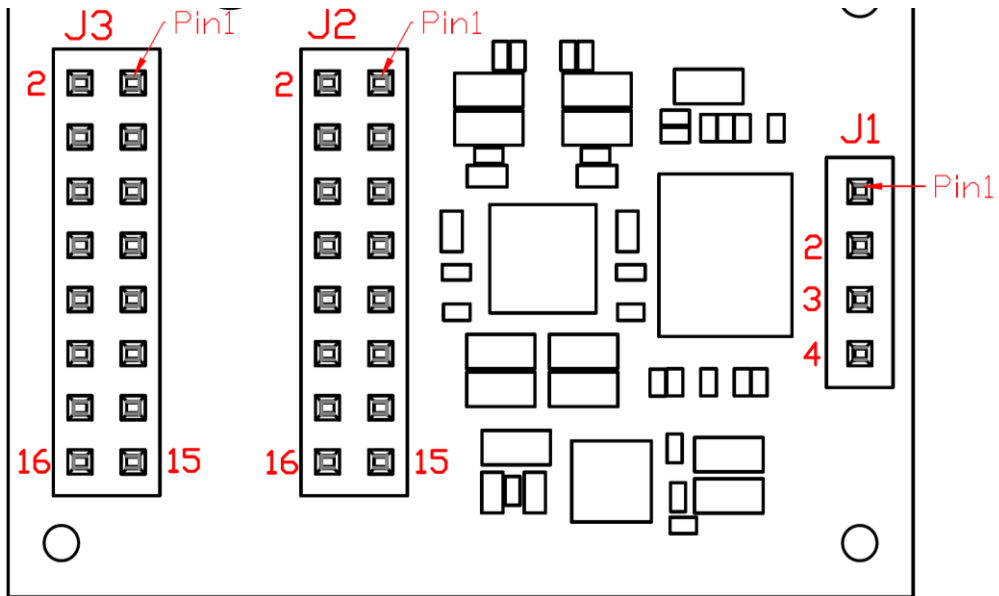

Figure 2-2. MT5A61-01 CONN drawing

J1 Pin define

Pin No.	Signal Name	Description
1	GND	Ground.
2	GND	Ground.
3	VSYS_IN	Power supply input Typical 5V (Range 3.6V to 5.5 V.)
4	VSYS_IN	Power supply input Typical 5V (Range 3.6V to 5.5 V.)

J2 Pin define

Pin No.	Signal Name	Description
1	AWR_SDA	I2C Data.
2	SOP1	Sense On Power - Line#1.
3	AWR_SCL	I2C Clock.
4	GND	Ground.
5	AWR_TMS	JTAG Test Mode Signal.
6	GND	Ground.
7	AWR_TCK	JTAG Test Clock.
8	GND	Ground.

9	AWR_TDO	JTAG Test Data Output.
10	WR_SPI_HOST_INTR	Out of Band Interrupt to an external host communicating over SPI.
11	AWR_TDI	JTAG Test Data Input.
12	GND	Ground.
13	UARTA_RX	UART A Receive.
14	AWR_NRST	Power on reset for chip. Active low
15	UARTA_TX	UART A Transmit.
16	SOP2	Sense On Power - Line#2

J3 Pin define

Pin No.	Signal Name	Description
1	RESERVED1	No need to connect.
2	RESERVED2	No need to connect.
3	RESERVED3	No need to connect.
4	AWR_MSS_LOGGER	Data UART Transmit.
5	GND	Ground.
6	GND	Ground.
7	UARTB_RX	UART B Receive.
8	AWR_SPI_MISO	SPI - Master In Slave Out.
9	AWR_GPIO_0	General-purpose I/O.
10	AWR_SPI_CLK	SPI – Clock.
11	AWR_GPIO_1	General-purpose I/O.
12	AWR_SPI_MOSI	SPI - Master Out Slave In.
13	GND/GPIO_2	UART B Transmit.
14	AWR_SPI_CS	SPI - Chip Select
15	GND	Ground.
16	GND	Ground.

2.3. Recommended Operating

PARAMETER		Min	Typ	Max	Units
VSYS_IN	DC supply input	3.6	5	5.5	V
VIH	IO high-level input voltage	2.25			
VIL	IO low-level input voltage			0.62	
Operating temperature		-40		85	°C

2.4. Power Consumption

PARAMETER	CONDITION		DESCRIPTION	Typ	Units
Average power Consumption based on VSYS_IN 5V.	People counting application v2.5.2 for testing	1TX, 4RX	Low power mode, 2.5 MSps complex transceiver, 50-ms frame time, 128 samples/chirp, 128 chirps, 30- μ s interchirp time (15% duty cycle), DSP active	2.03	W
		2TX, 4RX		2.1	
		1TX, 4RX	Low power mode, 2.5 MSps complex transceiver, 50-ms frame time, 128 samples/chirp, 256 chirps, 30- μ s interchirp time (30% duty cycle), DSP active	2.55	
		2TX, 4RX		2.72	

3. ANTENNA PERFORMANCE

The peak gain of MT5A61-01 Antenna is > 9 dBi across the operating frequency band of 76 to 81 GHz. The peak output power with the antenna gain around 25 dBm EIRP. The radiation pattern of the antenna in the horizontal plane (H-plane , Phi = 0 degrees) and elevation plane (E-plane , Phi= 90 degrees) is shown in Figure 3-1.

H-plane

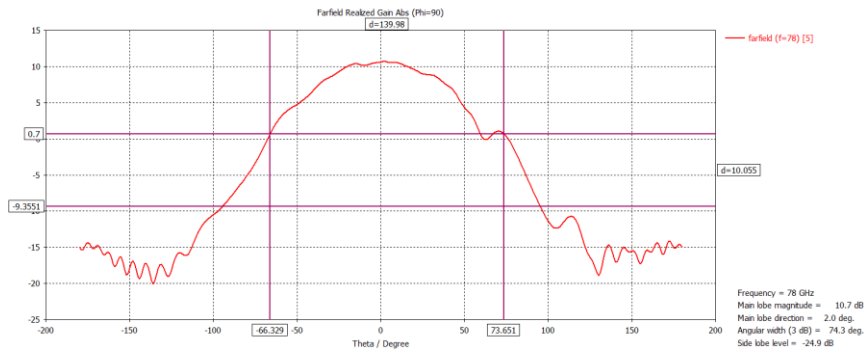

E-plane

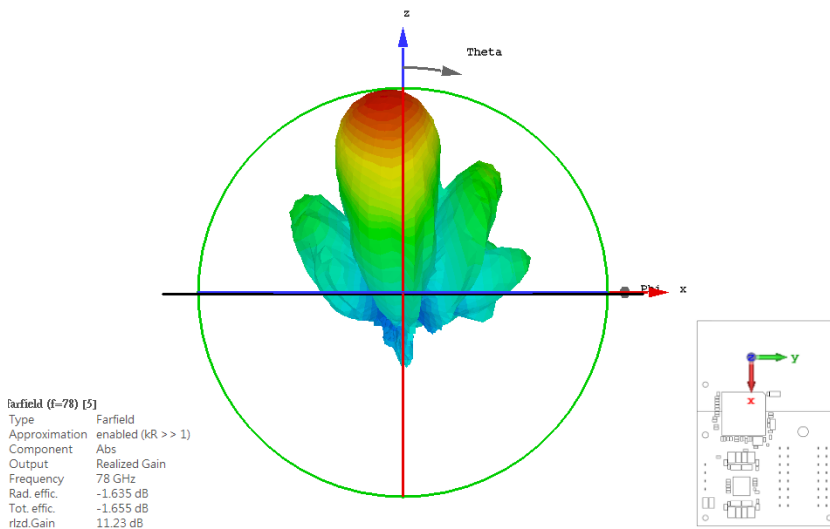
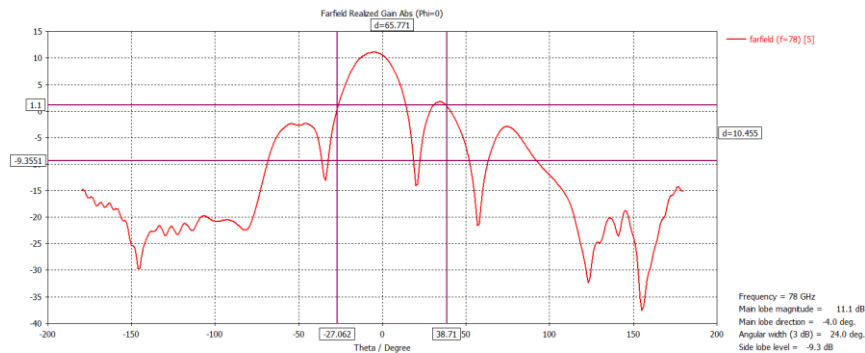

Figure 3-1. Antenna Pattern

4. REFERENCE DESIGN

4.1. Reference Schematic

Figure 4-1 to 4-3 shows the MT5A61-01 reference schematic.

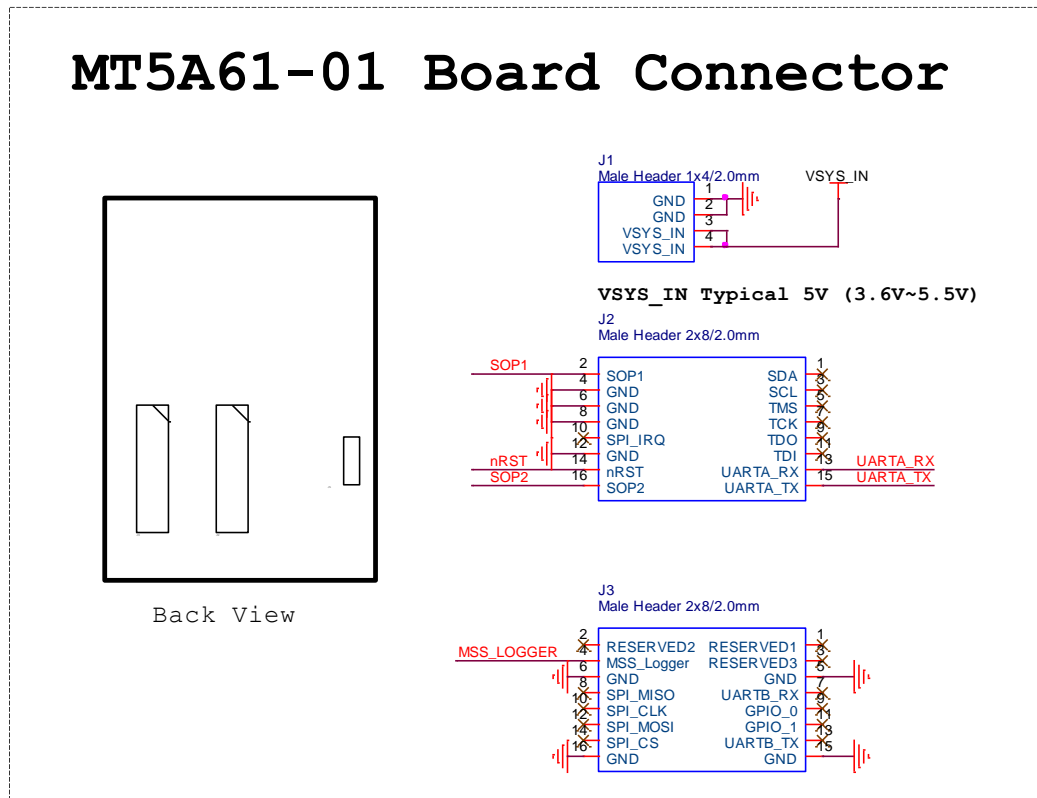

Figure 4-1. Board Connector of MT5A61-01 device

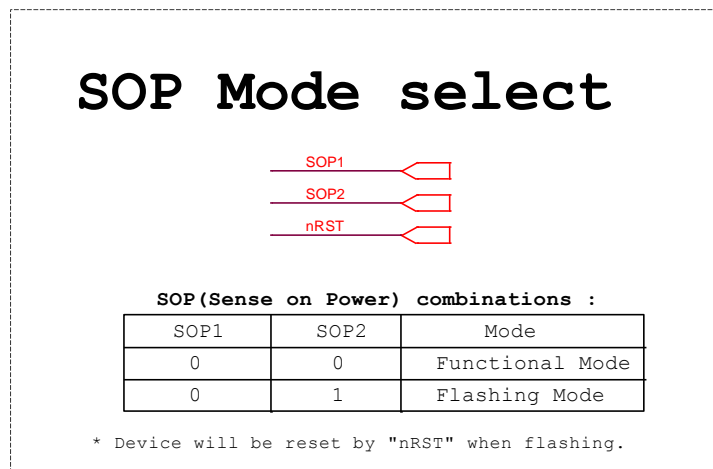

Figure 4-2. SOP mode of MT5A61-01 device

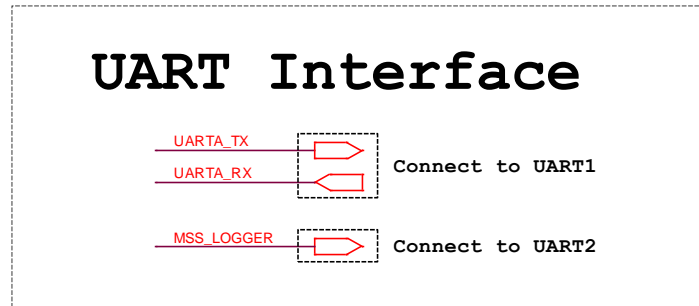

Figure 4-3. UART of MT5A61-01 device

4.2. mmWave Antenna Note

The mmWave Antenna is very sensitive that be notice some item as below:

1. Do not use metal of the product case around mmWave Antenna area.
2. The distance should be more than 5mm between mmWave Antenna and the product case.

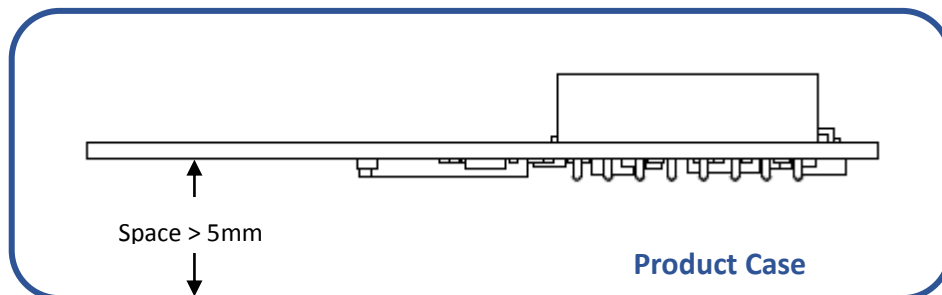

Figure 4-4. mmWave Antenna note

5. FUNCTION DESCRIPTION

5.1. Memory Flashing

Changed SOP mode to flashing mode.

SOP1	SOP2	Mode
0	1	Flashing Mode

Figure 5-1. shows the Flash Programmer. To view the flash tool, see [UniFlash](#).

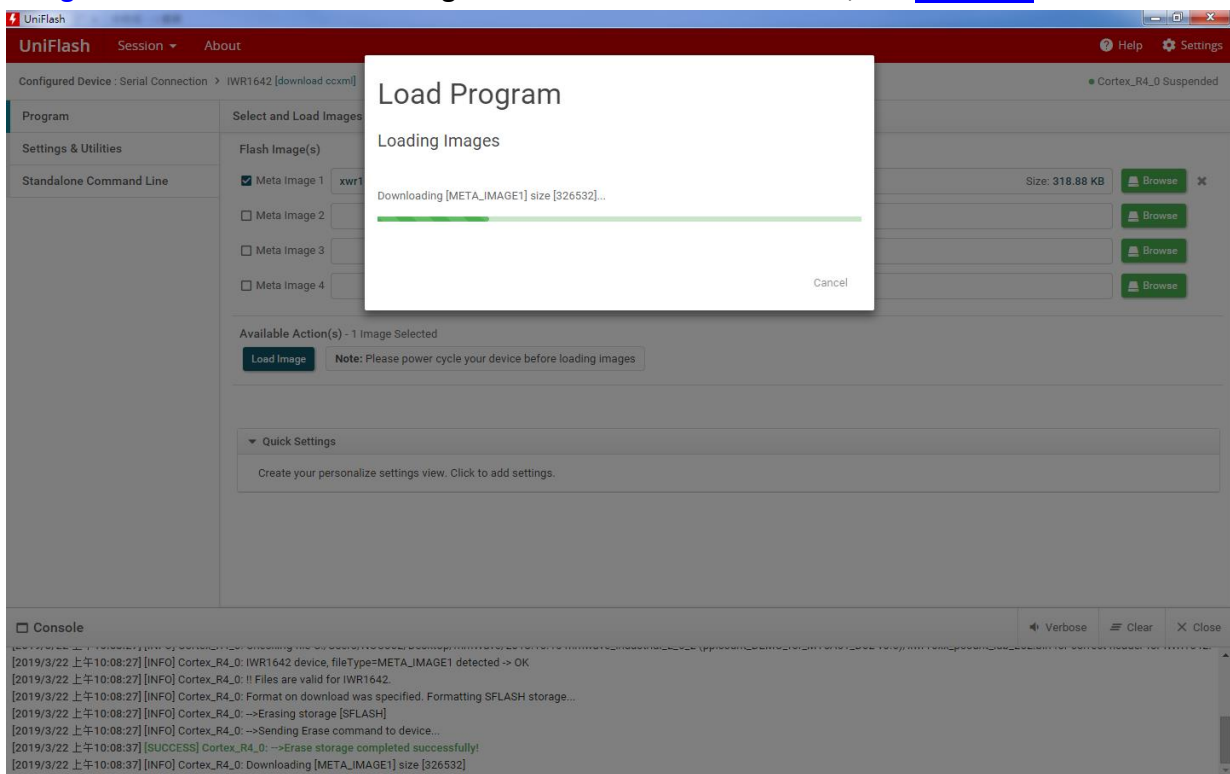

Figure 5-1. Flash Programmer

5.2. Testing Setup

Changed SOP mode to Functional mode.

SOP1	SOP2	Mode
0	0	Functional Mode

Figure 5-2 to 5-3. shows the testing setup. Setting a detecting environment, there are 6 subjects (4 red and 2 yellow points). To view the test tool, see [mmWave Demo Visualizer](#).

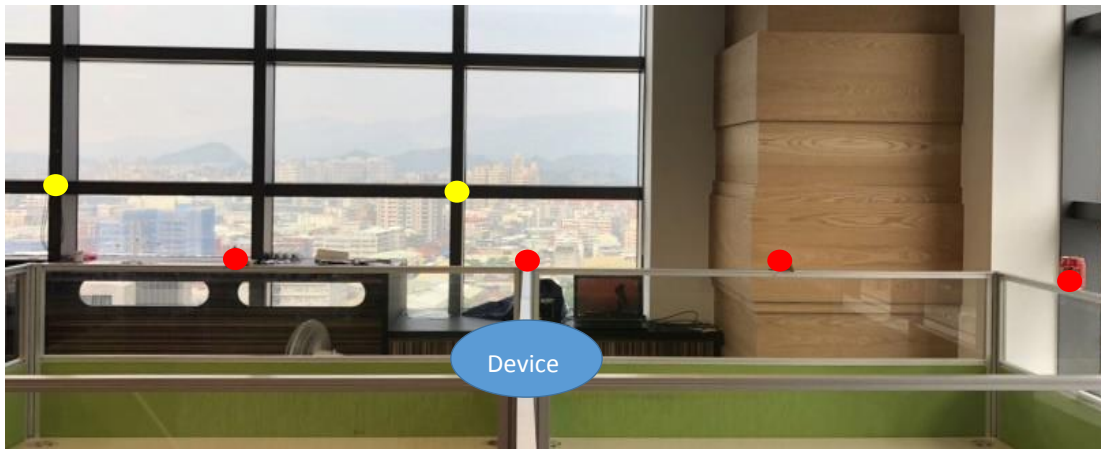

Figure 5-2. Detecting environment setting

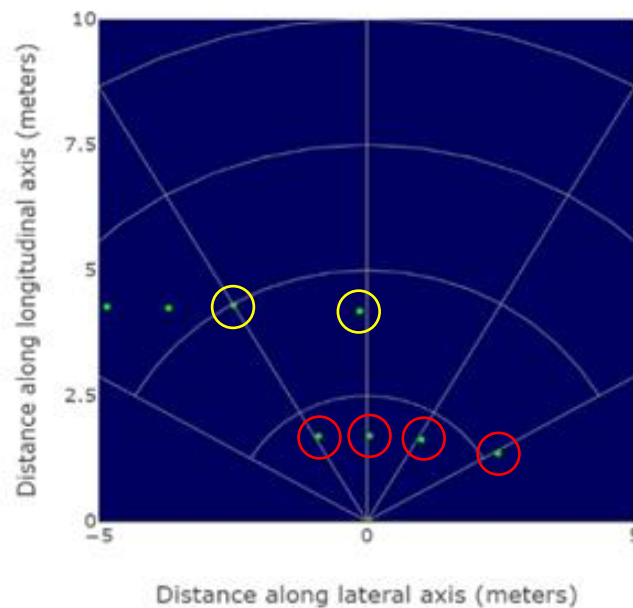

Figure 5-3. mmWave detecting result

6. DEVICE DIMENSION

Figure 6-1 shows the MT5A61-01 sensor device dimension.

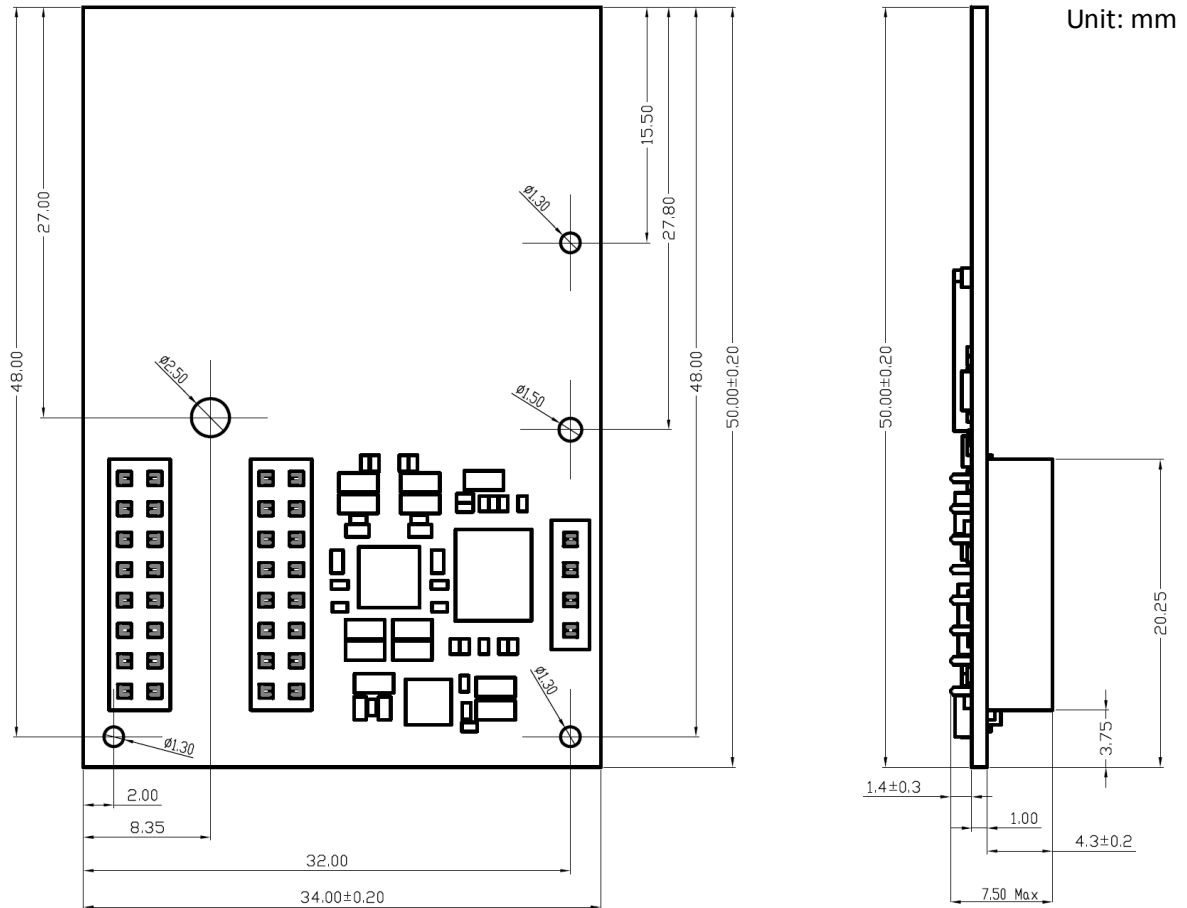

Figure 6-1. MT5A61-01 Device Dimension

7. SOFTWARE INFORMATION

7.1. Software Development Kit

The mmWave device design that based on TI IWR1642 ES2.0. The software development kit (SDK) includes demo codes 、 software drivers 、 emulation packages for debug and more that can be found at [mmwave-sdk](#).

7.2. Programming Tool

The UniFlash Programmer for Texas Instruments devices that provides a single interface for programming Flash memory and executing Flash based operations on supported targets. Can be found at [UniFlash](#).

7.3. Application Resource

There are some application experiments at [TI Resource Explorer](#) include people counting 、 traffic monitoring 、 vital signs and more that help to understand the design detail.

8. ORDERING INFORMATION

Sensor Device Part number:	MT5A61-01
----------------------------	-----------

9. HISTORY CHANGE

Revision	Date	Description
Draft 0.1	2019-03-22	Draft version.